

↔ DOMETIC

FreshWell 3000

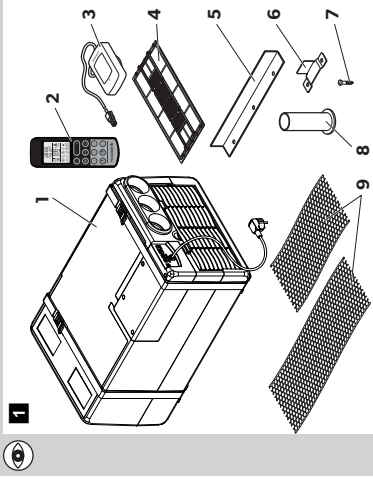

1

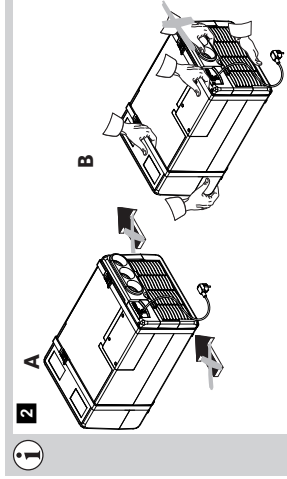

2

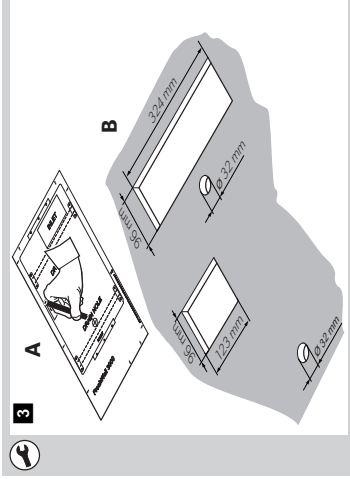

3

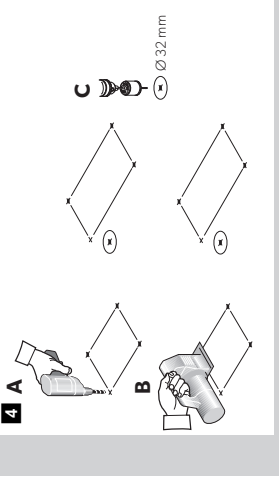

4



5

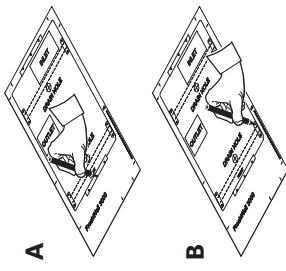

A

B

6

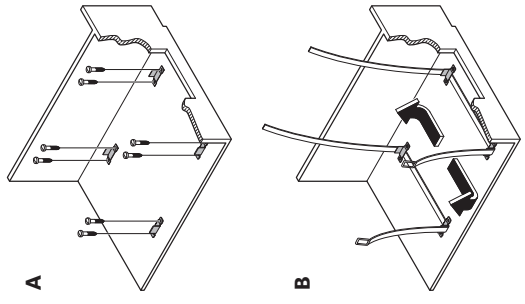

A

B

C

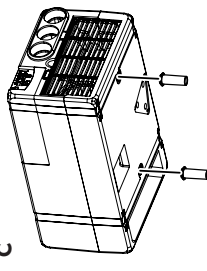

D

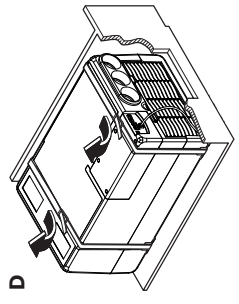

Domestic VAECO International GmbH
Hollerfeldstrasse 63
D-48282 Ernsbeiten
dometic.com

↔ DOMETIC

4445101820 ST0194 8250201-98 03/2017

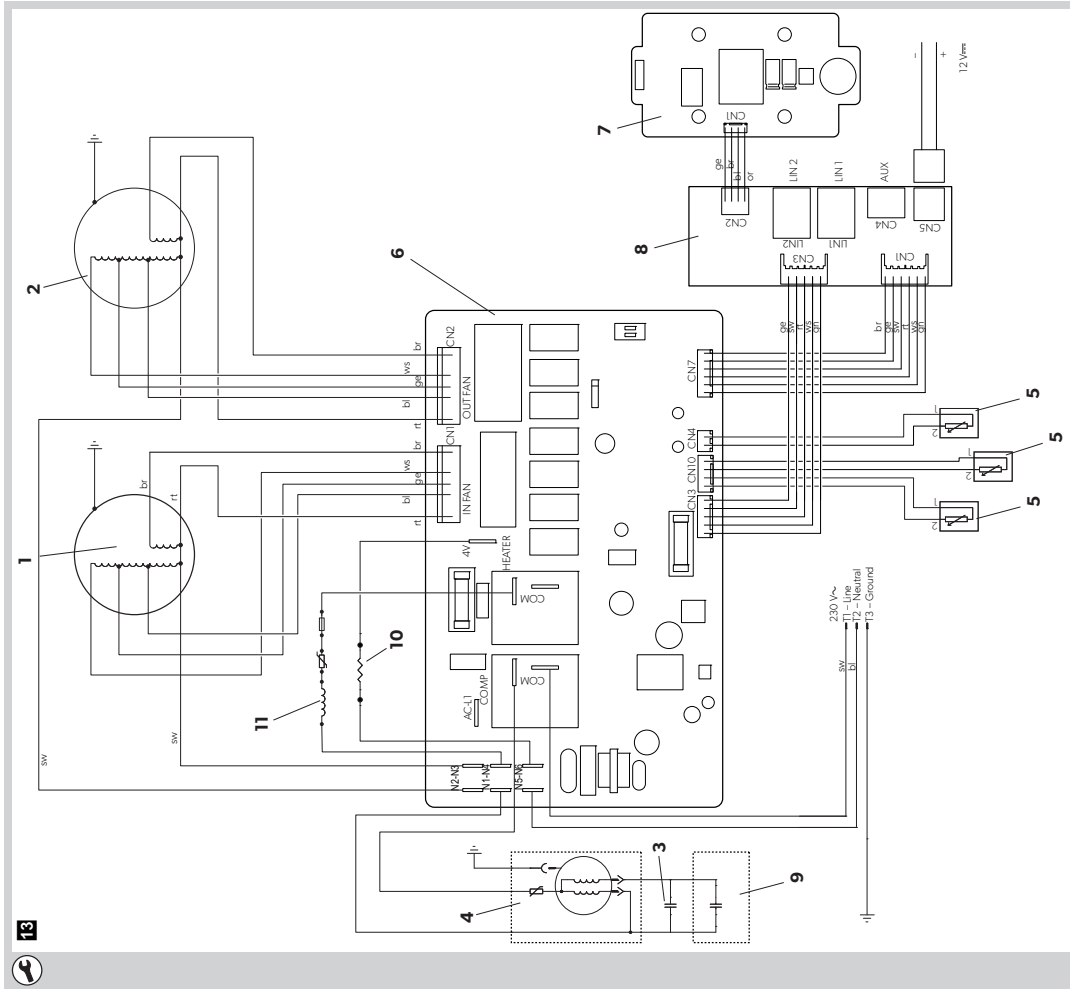

EN	DE	FR	ES	PT	IT	NL	DA	SV	NO	FI	RU	PL	SK	CS	HU
bl	Blue	Bleu	Azul	Azul	Blu	Blauw	Blå	Blå	Blå	Blå	Синий	Niebieski	Modrá	Modrá	Kék
br	Brown	Marron	Marrón	Castanho	Marrone	Bruin	Brun	Brun	Brun	Brun	Коричневый	Brązowy	Hnědá	Hnědá	Barna
cy	Cyan	Bleu	Cyan	Ciano	Cyan	Cyaan	Cyan	Cyan	Cyan	Cyan	Голубой	Cyan	Azurová	Azurová	Cian
ge	Yellow	Gelb	Jaune	Amarillo	Giallo	Geel	Gul	Gul	Gul	Gul	Желтый	Zółty	Zlta	Zlta	Sárga
gr	Green	Grün	Vert	Verde	Verde	Groen	Grøn	Grøn	Grøn	Grøn	Зеленый	Zielony	Zelená	Zelená	Zöld
gr	Grey	Grau	Gris	Cinzenlo	Grigio	Grijs	Grå	Grå	Grå	Grå	Серый	Szary	Sivá	Sivá	Szürke
or	Orange	Orange	Orange	Naranja	Corde laranja	Oranje	Orange	Orange	Orange	Orange	Оранжевый	Pomarańczowy	Oranžová	Oranžová	Narancs
pk	Pink	Rosa	Rose	Rosa	Cor de rosa	Roze	Lyserede	Rosa	Rosa	Rosa	Розовый	Różowy	Růžová	Růžová	Rózsaszín
rt	Red	Rouge	Rouge	Vermeillo	Rosso	Rood	Röd	Röd	Röd	Röd	Красный	Czerwony	Cervená	Cervená	Piros
sw	Black	Schwarz	Noir	Negro	Preto	Zwart	Sort	Sort	Sort	Sort	Черный	Czarny	Čierna	Čierna	Fekete
vt	Violet	Violet	Violeta	Lila	Violetto	Pairs	Violet	Violet	Violet	Violet	Фиолетовый	Fioletowy	Fialová	Fialová	Ibolya
ws	White	Weiß	Blanc	Bianco	Bianco	Wit	Hvid	Hvid	Hvit	Hvit	Белый	Biały	Bilá	Bilá	Fehér

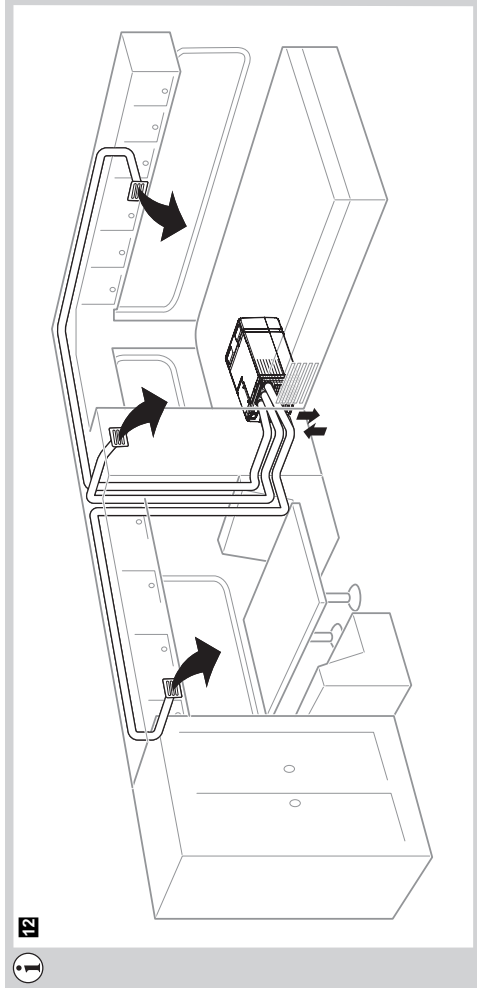
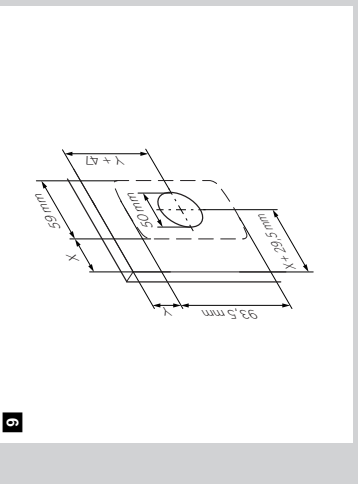
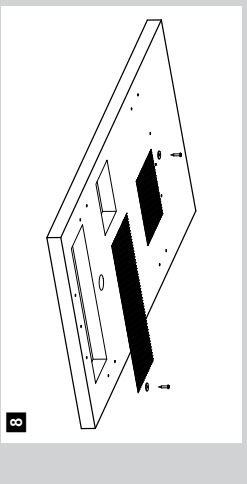
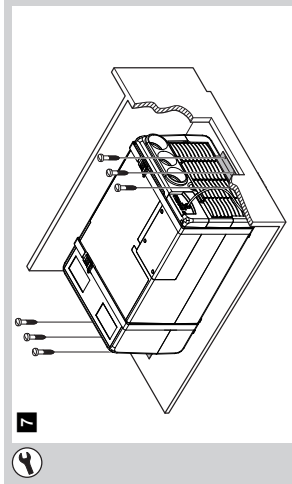
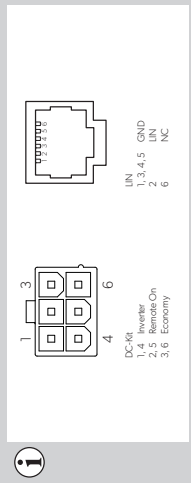
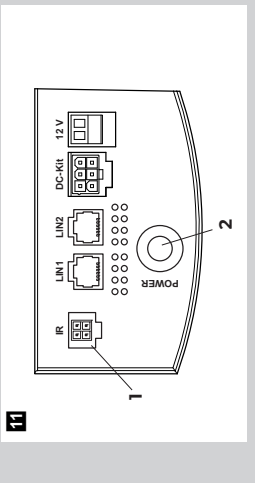
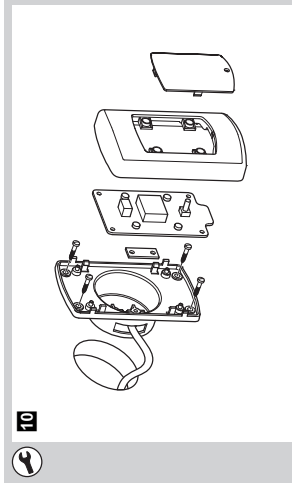

↗ DOMETIC

AIR CONDITIONERS FRESHWELL



FW 3000

- | | | |
|-----------|---|-----|
| EN | Under-bench air conditioner
Installation Manual..... | 2 |
| DE | Staukastenklimaanlage
Montageanleitung..... | 17 |
| FR | Climatiseur de coffre
Instructions de montage..... | 33 |
| ES | Equipo de aire acondicionado de cajón
Instrucciones de montaje..... | 49 |
| PT | Sistema de climatização para caixa de arrumação
Instruções de montagem..... | 65 |
| IT | Climatizzatore per vano di carico
Indicazioni di montaggio..... | 82 |
| NL | Airco onder de bank
Montagehandleiding..... | 97 |
| DA | Klimaanlæg til montering i et magasin
Monteringsvejledning..... | 114 |
| SV | Klimatanläggning för förvaringsutrymmen
Monteringsanvisning..... | 130 |
| NO | Takboks-klimaanlegg
Monteringsanvisning..... | 144 |
| FI | Kaappi-ilmastointilaite
Asennusohje..... | 159 |
| RU | Встраиваемый в багажный ящик кондиционер
Инструкция по монтажу..... | 174 |
| PL | Klimatyzator umieszczony w schowku
Instrukcja montażu..... | 190 |
| SK | Klimatizačné zariadenie do úložného priestoru
Návod na montáž..... | 205 |
| CS | Klimatizace do zavazadlového prostoru
Návod k montáži..... | 219 |
| HU | Tárolóládás klímaberendezés
Szerelési útmutató..... | 233 |

Please read this instruction manual carefully before installation and first use, and store it in a safe place. If you pass on the product to another person, hand over this instruction manual along with it.

Table of contents

1	Explanation of symbols	2
2	Safety and installation instructions	3
3	Target group for this instruction manual	4
4	Scope of delivery	5
5	Intended use	5
6	Labels	5
7	Installation	6
8	Troubleshooting	12
9	Disposal	13
10	Technical data	15

1 Explanation of symbols



WARNING!

Safety instruction: Failure to observe this instruction can cause fatal or serious injury.



CAUTION!

Safety instruction: Failure to observe this instruction can lead to injury.



NOTICE!

Failure to observe this instruction can cause material damage and impair the function of the product.



NOTE

Supplementary information for operating the product.

2 Safety and installation instructions

Please observe the prescribed safety instructions and stipulations from the vehicle manufacturer and service workshops.

The manufacturer accepts no liability for damage in the following cases:

- Damage to the product resulting from mechanical influences and excess voltage
- Alterations to the product without express permission from the manufacturer
- Use for purposes other than those described in the operating manual

Note the following basic safety information when using electrical devices to protect against:

- Electric shock
- Fire hazards
- Injury

2.1 Handling the device



WARNING!

- Installation and repair of the under-bench air conditioner may only be carried out by qualified personnel who are familiar with the risks involved and the relevant regulations. Inadequate repairs may cause serious hazards. For repair service, please contact the service centre in your country (addresses on the back page).
- **Electrical devices are not toys.**
Keep electrical devices out of reach of children or infirm persons. Do not allow them to use electrical devices without supervision.
- Persons whose physical, sensory or mental capabilities or whose lack of experience and knowledge prevent them from using the device safely should not use it without supervision or instruction by a responsible person.
- In the event of a fire only use approved extinguishing agents. Do not use water to extinguish fires.



CAUTION!

- The under-bench air conditioner must be installed securely so that it cannot fall down.
- Only operate the under-bench air conditioner if you are certain that the housing and the cables are not damaged.

- Do not use the under-bench air conditioner near flammable fluids.
- Make sure no combustible objects are stored or installed near the air outlet. A distance of at least 50 cm must be kept.
- Do not reach into air outlets or insert any foreign objects in the device.

**NOTICE!**

- Only use the device as intended.
- The under-bench air conditioner is not suitable for use in agricultural or construction vehicles.
- Do not make any alterations or conversions to the device.
- If faults occur in this refrigerant circuit, the system must be checked by a specialist company and repaired properly. The refrigerant must never be released into the air.

2.2 Handling electrical cables

**WARNING!**

- The electrical power supply may only be connected by a qualified electrician (e.g. VDE 0100, Part 721 in Germany).

**CAUTION!**

- Attach and lay the cables so that they cannot be tripped over or damaged.

**NOTICE!**

- Use cable ducts to lay cables through walls with sharp edges.
- Do not lay loose or bent cables next to electrically conductive materials (metal).
- Do not pull on the cables.

3 Target group for this instruction manual

The instructions in this manual are intended for qualified personnel at workshops who are familiar with the guidelines and safety precautions to be applied.

4 Scope of delivery

No. in fig. 1	Quantity	Description
1	1	Under-bench air conditioner
2	1	Remote control
3	1	Receiver
4	4	Air filter
5	2	Angle section
6	4	Fastening bracket
7	14	Fastening screw
8	2	Drain pipe
9	2	External grids
-	1	Assembly template

5 Intended use

The Dometic FreshWell 3000 under-bench air conditioner (ref. no. 9105306670) is designed for use in motorcaravans, caravans and other vehicles with habitation compartments only. It is **not** suitable for houses and apartments.

The under-bench air conditioner is **not** suitable for installation in construction machines, agricultural machines or similar equipment. It will not work properly if exposed to strong vibrations.

The operating mode of FreshWell 3000 is guaranteed for temperatures between 0 °C and 52 °C.



NOTE

You can find additional information on under-bench air conditioners in the operating manual, such as the technical description or the controls.

6 Labels

Labels are attached to the Dometic FreshWell under-bench air conditioners. These labels provide the user and fitter with information on specifications of the device.

7 Installation



CAUTION! Beware of injury

The under-bench air conditioner may only be installed by qualified personnel from a specialist company. The following information is intended for technicians who are familiar with the guidelines and safety precautions to be applied.

7.1 Note on installation

Read this installation manual completely before installing the under-bench air conditioner.

The following tips and instructions must be observed while installing the under-bench air conditioner:



DANGER! Danger of electrocution

Disconnect all power supplies when working on the under-bench air conditioner.



CAUTION! Beware of injury

- Improper installation of the under-bench air conditioner can result in irreparable damage to the device and put the safety of the user at risk.
- The manufacturer assumes no liability for malfunctions and for the safety of the under-bench air conditioner, especially for injury and/or damage to property, if the under-bench air conditioner is not fitted in accordance with these installation instructions.
- Always wear the recommended protective clothing (e.g. protective goggles, gloves).



NOTICE! Beware of damage

Observe the structural engineering of the vehicle and seal of all openings made when installing the under-bench air conditioner.

Note on transport

- Always have someone help you carry the under-bench air conditioner.
- Always lift the under-bench air conditioner to move it and never drag it over the floor (fig. **2 A**).
- Do not use the ventilation slots to lift it (fig. **2 B**).

Note on installation location

- To install the machine it is necessary to create openings in the floor. These openings must be accessible and must not be covered by any parts of the vehicle.
- Before installing the under-bench air conditioner, check whether any vehicle components could be damaged by the installation of the under-bench air conditioner (such as lamps, cupboards, doors).
- Make sure no combustible objects are stored or installed near the air outlet. A distance of at least 50 cm should be kept.
- The inclination of the installation surface may not exceed 10°.
- For safety reasons, note the location of existing wiring harnesses, wires and other components within the installation area, in particular those which are not visible, when installing the under-bench air conditioner (when drilling or screwing etc.).
- To obtain the optimal air-conditioning in the vehicle, install the under-bench air conditioner in a central position, in a compartment or a similar housing.
- Choose a place that is easily accessible for servicing as well as disassembling and installing.
- Place the assembly template into the chosen compartment and check the space available for the openings in the floor.
- To minimize the transmission of noise and vibration during operation, the under-bench air conditioner should have a all around minimum clearance of 30 mm to walls and furniture.
- The under-bench air conditioner must be installed on the floor.
- Keep a distance of 200 mm between the front of the under-bench air conditioner and the walls of the compartment to facilitate filter replacement.
- Installing the under-bench air conditioner into an external compartment (e.g. false bottoms), the air to be treated must be drawn in from the vehicle's passenger compartment.
- Suctioning of outside air can significantly reduce the power of the system.

Note on electrical system (see fig. 13)

No. in fig. 13	Description
1	Motor ventilator (inner)
2	Motor ventilator (outer)
3	Capacitor
4	Compressor
5	Temperature sensor
6	PCB
7	PCB display
8	PCB interface
9	Soft start
10	Valve
11	Resistor

- Only a qualified electrician should connect the under-bench air conditioner to the electrical power.
- Check that the voltage specification on the type plate is the same as that of the power supply.
- Do not lay cables which are loose or bent next to electrically conductive material (metal).
- Install an all-pole switch with a contact opening width of at least 3 mm on the installation side.

7.2 Making openings

See fig. 3

- Mark the position and size of the openings using the template included in the packaging (**A** and **B**).

See fig. 4

- Drill out the corners (**A**).
- Carefully cut out the opening on the roof using a keyhole saw or a similar tool (**B**). Make sure no electrical power cables are damaged.
- Drill out a condensation water drainage opening with a diameter of 32 mm (**C**).

See fig. 5

- Mark the position of the angle sections (**A**) and the fastening brackets (**B**).

7.3 Installing the fastening brackets and belts

See fig. 6

- Fasten the four fastening brackets (**A**).
- Pull the belts through the fastening brackets (**B**).
- Install the drain pipes under the under-bench air conditioner (**C**).
- Fasten the under-bench air conditioner with the belts (**D**).

7.4 Installing the angle section

See fig. 7

- Fasten the under-bench air conditioner with the two angle sections and three fastening screws for each as shown.

7.5 Installing the external grids

See fig. 8

- Fasten the external grids as shown with the screws and washers included in the supply.

7.6 Installing the receiver

See fig. **9**

- Drill an opening of 50 mm into the wall.

See fig. **10**

- Lay the cable through the hole to the under-bench air conditioner.
- Fasten the receiver as shown.

7.7 Laying the connecting cables



DANGER! Danger of electrocution

Make sure there is no voltage at electrically operated components before carrying out work on them!

The under-bench air conditioner must be connected to an electric circuit which is able to supply the required current (see chapter "Technical data" on page 15).

- Select the cross-section of the cable corresponding to the length:
 - Length < 7.5 m: 1.5 mm²
 - Length > 7.5 m: 2.5 mm²

See fig. **11**

- Plug the four-pole plug of the receiver into the IR socket of the **(1)**.
- Plug the 230 V~ plug into an 230 V~ socket **(2)**.

7.8 Air ducting

See fig. 12

Make the air ducting with trade parts (**not** included in the supply). It is recommended to use cardboard pipe for air conditioning with an aluminium core and external covering of PVC. The nominal inside diameter should size up to 60 mm, the outside diameter 65 mm.

The ventilation pipes are joined by pressing them together thanks to the tapered hole on the air outlet.

The pipes are connected to the register output.

To achieve the best efficiency it is recommended to:

- lay the air pipes as short and straight as possible
- restrict the length of the pipes to 5 m
- don't lay the pipes near any heat sources

The recirculation air is drawn in through a grille or through other openings with a total cross-section of at least 300 cm². The recirculation air opening must be created near the machine. If this is not possible, make sure that the air flow must be obstructed by anything; if necessary, create an air duct between the opening and the machine.



NOTE

To avoid condensation on the pipes insulate the pipes with insulation material (not included in the scope of delivery).

The recirculation air must be taken from inside the passenger compartment; if taken from the outside then the efficiency of the under-bench air conditioner will be reduced.

8 Troubleshooting

Problem	Cause	Remedy
No cooling capacity	The under-bench air conditioner is not set to cooling.	➤ Set the under-bench air conditioner to cooling.
	The ambient temperature is above 52 °C.	The under-bench air conditioner is only designed for ambient temperatures of up to 52 °C.
	The temperature set is higher than the room temperature.	➤ Select a lower temperature.
	The ambient temperature is below 16 °C.	The under-bench air conditioner is only designed for ambient temperatures above 16 °C.
	The thermal protection is defective.	➤ Contact an authorised workshop.
	The compressor is damaged.	
	The refrigerating agent filling is insufficient.	
	The heat exchange coils are polluted.	
	The external blower is defective.	
No heating capacity	The under-bench air conditioner is not set to heating.	➤ Set the under-bench air conditioner to heating.
	The ambient temperature is below 0 °C.	The under-bench air conditioner is only designed for ambient temperatures higher than 0 °C.
	The temperature set is lower than the room temperature.	➤ Select a higher temperature.
	The ambient temperature is higher than 31 °C.	The temperature is adjustable between 16 °C and 31 °C.
	The thermal protection is defective.	➤ Contact an authorised workshop.
	The compressor is damaged.	
	The refrigerating agent filling is insufficient.	
	The heat exchange coils are polluted.	
	The external blower is defective.	
Low air output	The air filter is obstructed.	➤ Clean the air filter.
	The heat exchange coils are polluted.	➤ Contact an authorised workshop.
	The internal blower is defective.	

Problem	Cause	Remedy
Water enters the vehicle	The condensation water drainage openings are clogged up.	➤ Clean the drainage openings for condensation water.
	The seals are damaged.	➤ Contact an authorised workshop.
Under-bench air conditioner does not switch on.	No supply voltage (230 V~) connected.	➤ Check the power supply.
	The voltage is too low (under 200 V~). The voltage converter is defective.	➤ Contact an authorised workshop.
	The defective thermal protection is defective.	
	The electrical fuse of the power supply is too low.	➤ Check the electrical fuse of the power supply.
Under-bench air conditioner stops working.	The air filter is obstructed.	➤ Clean the air filter.
	The voltage is too low (under 200 V~). The voltage converter is defective.	➤ Contact an authorised workshop.
	The defective thermal protection is defective.	
	The condenser fan is damaged.	
	The heat exchange coils are polluted.	
	The external blower is defective.	
Under-bench air conditioner does not switch off.	One of the temperature sensors is defective.	➤ Contact an authorised workshop.

9 Disposal

Regulations for environmental safety and correct disposal

All organisations must apply a set of procedures to identify, evaluate and control the influence that their activities (manufacturing, products, services, etc.) have on the environment.

The procedures to be followed to identify significant environmental impact must take the following factors into account:

- use of raw materials and natural resources
- atmospheric emissions
- discharge of liquids

- waste management and recycling
- contamination of the soil

In order to minimise environmental impact, the manufacturer provides a series of indications here below that should be taken into account by all those who, for whatever reason, interact with the appliance during its working life.

- All packing components must be disposed of (preferably recycled) in compliance with statutory legislation in the country in which disposal takes place.
- All product components must be disposed of (preferably recycled) in compliance with statutory legislation in the country in which disposal takes place.
- For correct disposal, the appliance must be consigned to an authorised waste disposal company to ensure that all recyclable components are reused and the remaining materials are processed properly.
- During installation ensure the room has adequate ventilation to prevent the build-up of stale air that might be harmful to the health of the operators.
- During operation and maintenance ensure that any waste pollutant products (oil, grease, etc.) are disposed of correctly.
- Keep noise levels down to reduce noise pollution.

For more information on correct dismantling of our products please refer to the recycling handbooks at www.dometic.com.

- Place the packaging material in the appropriate recycling waste bins wherever possible.
- When in operation or undergoing repairs and maintenance work, make sure that the refrigerant circuit is not damaged and refrigerant cannot escape. It acts as a greenhouse gas and should not be allowed into the environment.



If you wish to finally dispose of the product, ask your local recycling centre or specialist dealer for details about how to do this in accordance with the applicable disposal regulations.

- Dispose of the product at an official waste disposal facility in accordance with the applicable recycling or disposal guidelines.



Protect the environment!

Do not dispose of any batteries with general household waste. Return defective or used batteries to your retailer or dispose of them at collection points.

10 Technical data

	FreshWell 3000
Ref. no.:	9105306670
Cooling capacity according to ISO 5151:	2700 W
Heating capacity:	3000 W (2500 W + 500 W additional heating element)
Rated input voltage:	230 V~ / 50 Hz
Current consumption:	Cooling: 4.3 A Heating: 4.8 A
Required fuse:	5 A
Operating temperature range:	0 °C to +52 °C
Refrigerant:	R-410A
Refrigerant quantity:	0.6 kg
CO ₂ equivalent:	1,2528 t
Global warming potential (GWP):	2088
Additional heating element:	500 W
Blower:	3 blower levels 1 Automatic mode
Protection class:	IP X5
Max. volume of space in the vehicle (with insulated walls):	30 m ³
Dimensions L x W x H:	628 x 400 x 286 mm

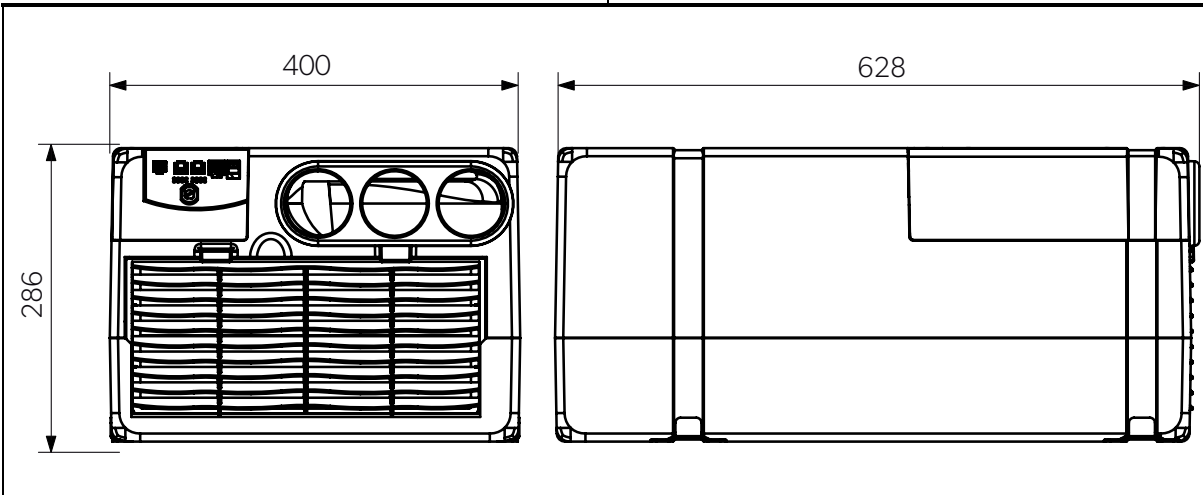
FreshWell3000	
	
Weight:	approx. 21 kg
Inspection/certification:	CE

Contains fluorinated greenhouse gases

Hermetically sealed equipment